

PRODUCT SPECIFICATION

139 Diameter Micro Drums



Photo shows obsolete handle

DRUM SPECS

Drum Details	2 Litre	2 Litre	2 Litre
Ullage % (approx)	13	11	11
Height (mm) exc handle	157	157	157
Height (mm) inc handle	172	172	172
Fitting	44mm Screw	REL	DIN
Embossing (optional)	POISON	POISON	POISON
Packing Qty			
Bulk	No. per Layer	63	63
	No. per Pallet	441	441
Cartons	No. per Carton	28	28
	No. of Cartons	16	16
	No. per Pallet	448	448
Height Tolerance	±1mm		
Handle	4 finger plastic		
Options			
Dangerous Goods Status	Packing Group II / 1.2 max		
Print Area	Request artwork template from Account Manager		

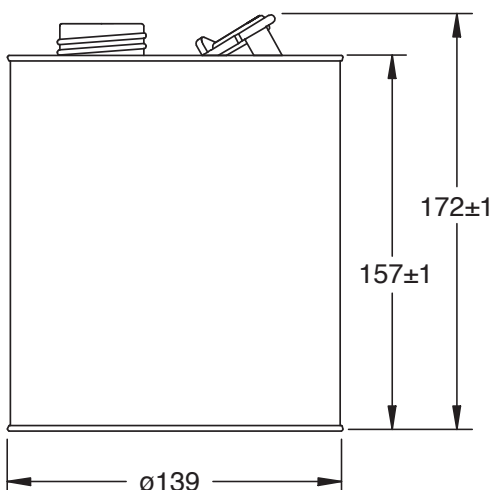

DRUM COATINGS

Outside	Plain	(POS)
	White	(WOS)
	Varnish	(VOS)
Inside	Plain	(PIS)
	Lacquer	(LIS)

Issue Date: 15 July 2015

www.ncipackaging.com

Sales & Enquiries:

AUSTRALIA
1800 289 624

metal.enquiries@ncipackaging.com
90-92 Chifley Drive, Preston, VIC 3072

NEW ZEALAND
0800 220 120

windsor.yang@ncipackaging.com
80 Mt Wellington Hwy Panmure Auckland

NCI Packaging

PRODUCT SPECIFICATION

Appendix

COATINGS AND USES

Tinplate is steel sheet electroplated with tin to provide enhanced appearance and protection against rust. Coatings can be added to tinplate to enhance appearance and performance. Coatings and their typical uses* are listed below.

Outside	Plain	(POS) Use in dry environments where the risk of oxidation is low
	White	(WOS) Additional protection against oxidation of the container due to moisture Also used on most printed cans as the white base coating under colour print
	Varnish	(VOS) Clear finish for extra protection against oxidation of the container due to moisture
Inside	Plain	(PIS) Typical uses: Solvent based products Oil paints Edible oils Not suitable for: Water based products Olive oil
	Lacquer	(LIS) Typical uses: Water based products Water based paints Olive oil

** Uses above are suggestions only, customers are responsible for testing to ensure compatibility of containers with their packed product.*

www.ncipackaging.com

Sales & Enquiries:

AUSTRALIA
1800 289 624

metal.enquiries@ncipackaging.com
90-92 Chifley Drive, Preston, VIC 3072

NEW ZEALAND
0800 220 120

windsor.yang@ncipackaging.com
80 Mt Wellington Hwy Panmure Auckland